



**SkyGuardTWX “Vision-Pro Plus” 978mhz UAT ADS-B  
Transmitter  
Installation and Operation Manual  
(for use when remote installing in Experimental or LSA Aircraft)**

**Part Number:** UAT1000B-EX  
**FCC ID:** R83UAT1000

**Business Address:** SkyGuardTWX, LLC  
208 Sunday Drive  
Burnet, Texas 87611

**Phone Number:** 512-784-7766

**Email Address:** Don@SkyGuardTWX.com

**WEB Site:** www.SkyGuardTWX.com

**Document History**

<b>Revision</b>	<b>Date</b>	<b>Comments</b>
1.0	03/01/2015	Initial Release
1.1	08/01/2015	Updated specs. for new GPS

## Table of Contents

1.0	System Description .....	04
1.1	Reference Documents .....	05
1.2	Regulatory Compliance .....	06
1.2.1	TSO .....	06
1.2.2	TSO Authorization .....	06
1.2.3	FCC Grant of Equipment Authorization .....	06
2.0	Installation Limitations .....	07
2.1	Surveillance Services .....	07
2.2	Flight Manual Supplement .....	08
2.3	Other Considerations .....	08
3.0	Equipment Installation .....	09
3.1	Package Contents .....	09
3.2	Overall Specifications .....	10
3.3	System Interfaces .....	11
3.4	Antenna Requirements/Installation .....	11
3.5	Temperature/Air Flow Requirements .....	12
3.6	Installation Mounting .....	12
3.7	Electrical Connections .....	15
3.7.1	Power Connections .....	16
3.7.2	Display Connections .....	16
3.7.3	Transponder Connections .....	17
3.7.4	Annunciator Light Connections .....	17
4.0	Initial Configuration Programming .....	18
5.0	Post Installation Verification .....	19
5.1	Transmitter DC Power Verification .....	19
5.2	GPS Verification .....	20
5.3	Pressure Altitude Encoder Verification .....	20
5.4	UAT Transmitter Verification .....	20
5.5	1090 Receiver Verification .....	20
5.6	Annunciator Light Verification .....	20
6.0	Weight and Balance .....	21
7.0	Inflight Operation .....	21
8.0	Maintenance .....	22
8.1	Altitude Source .....	22
8.2	Calibration .....	22
8.3	Cleaning .....	22
8.4	Tune-Up .....	22
9.0	Warnings and Disclaimers .....	23

08/01/2015



## 1.0 System Description

This ADSB OUT Transmitter is a fully integrated 978mhz UAT ADS-B radio transmitter along with a WAAS GPS (non-certified version) and WiFi transmitter. The main unit also contains circuitry to interface with a panel mounted display and a Mode A/C/S transponder. This equipment is capable of broadcasting position, altitude, speed, heading, and other data to nearby aircraft as well as ADSB Ground Station Towers which will trigger the ADSB Ground Station Tower to begin transmitting local aircraft targets(TIS-B) back up to an ADSB IN Receiver. The non-TSO'd version of this transmitter (P/N: UAT1000B-EX) contains an internal non-certified GPS position source that will “meet the performance requirements of TSO-C199” when installed in an Experimental or LSA aircraft. This unit has been designed and tested to meet the performance requirements of 14 CFR 91.227 and TSO-C154c. This new FAA rule change was enacted on February 9, 2015 by changes to: 14 CFR 91.225 section b.1.ii. When installing in an LSA, a letter of authorization is required from the LSA manufacturer.

The unit is intended to be permanently installed and connected to aircraft power through a fused/switched dedicated power connection to the aircraft avionics power bus. The unit will operate utilizing a DC power source ranging from +10 volts to +30 volts with a minimum of 3 amps of current. There are 5 antennas connections (1- 978mhz for UAT transmitter, 1- 1090mhz for Transponder receiver, 1- for GPS antenna, 1 – for WiFi transmitter, and 1- for Transponder interrogator). All antennas (except UAT Transmitter) are intended to be mounted directly on the Transmitter. The UAT Transmitter antenna is intended to be mounted on the belly of the aircraft. The Transmitter installer will be responsible for purchasing the required external antenna and RF coax cable for the transmitter antenna.

See Figure 1 for system block diagram:

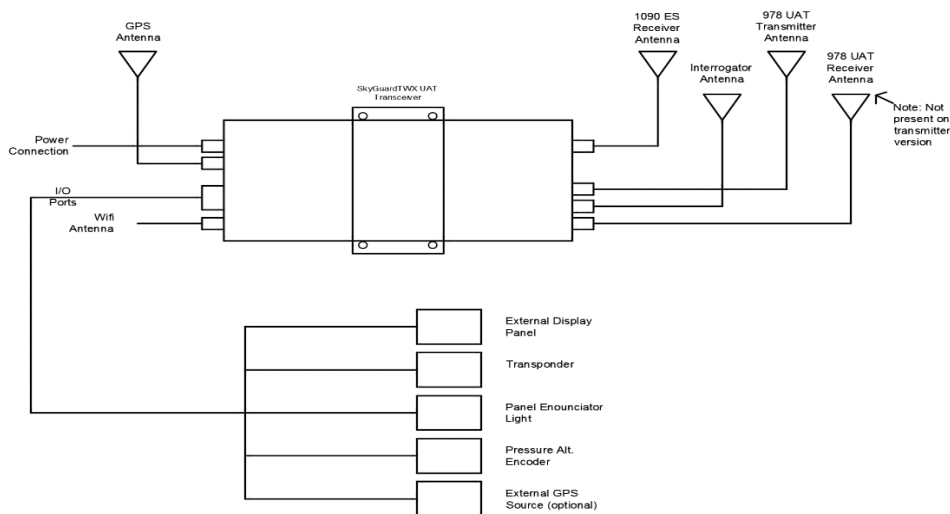

System Block Diagram  
Figure 1.

**1.1**

**Reference Documents**

RTCA/DO-282B	RTCA Document. Minimum Operational Performance Standards for Universal Access Transceiver (UAT) Automatic Dependent Surveillance – Broadcast (ADS-B)
RTCA/DO-160F	RTCA Document. Environmental Conditions and Test Procedures for Airborne Equipment.
TSO-C154c	Technical Standard Order Universal Access Transceiver (UAT) Automatic Dependent Surveillance-Broadcast (ADS-B) Equipment Operating on Frequency of 978MHz
TSO-C145c	Technical Standard Order for Airborne Navigation Sensors Using The Global Positioning System (GPS) Augmented By The Satellite Based Augmentation System (SBAS)
AC 20-165A	Airworthiness Approval of Automatic Dependent Surveillance-Broadcast (ADS-B) Out Systems
AC 20-138B	Airworthiness Approval of Global Navigation Satellite Systems (GNSS) Equipment
TSO-C190	Technical Standard Order for Active Airborne Global Navigation Satellite System (GNSS) Antenna
TSO-C199	Technical Standard Order for Traffic Awareness Beacon System
91.225	Equipment, Instrument, and Certificate Requirements
91.227	ADS-B Equipment Performance Requirements

08/01/2015

## 1.2 Regulatory Compliance

### 1.2.1 TSO

#### SkyGuardTWX Transmitter Part Numbers:

<b>TSO-C154c</b>	Universal Access Transmitter (UAT) Automatic Dependent Surveillance-Broadcast (ADS-B) Equipment Operating on Frequency of 978MHz. Unit “meets the performance requirements of TSO-C154c” when installed in Experimental or LSA aircraft per FAA rule change enacted on February 9, 2015.	<u>UAT1000B-EX</u>
------------------	--	--------------------

<b>1.2.2 Function</b>	<b>TSO</b>	<b>Minimum Performance Standard</b>	<b>Software RTCA/DO- 178B</b>	<b>Hardware RTCA/DO-254</b>	<b>Environmental</b>
UAT Transceiver	TSO-C154c Class B1S	RTCA/DO-282B	Level C	Level C	RTCA/DO-160F
GPS/WAAS Receiver	Non-TSO'd				RTCA/DO-160F

### 1.2.3 FCC Grant of Equipment Authorization

This equipment has been issued an FCC Grant of Equipment Authorization. The FCC ID is: R83UAT1000 and is also marked on the equipment nameplate.

## **2.0 Installation Limitations**

The conditions and tests required for approval of this article are minimum performance standards. Those installing this article, on or in an Experimental or LSA type class of aircraft, must determine that the aircraft installation conditions are within the TSO standards. TSO articles must have separate approval for installation in an aircraft. The article may be installed only according to 14 CFR part 91 or the applicable airworthiness requirements. The article must be installed according to AC 20-165 applicable airworthiness requirements. A “letter of conformance” from SkyGuardTWX LLC stating that the unit “meets the performance requirements of TSO-C154c and 91.227” is required.

The UAT Transmitter Antenna **MUST** be installed no less than 4 feet from any Distance Measuring Equipment (DME) antenna.

The UAT Transmitter Antenna **MUST** be installed no less than 4 feet from any Comm. Radio Antenna.

The UAT Transmitter 1090 Receiver Antenna **MUST** be installed no less than 2 feet from the UAT Transmitter 978 Antenna and no less than 3 feet from any L-Band (Transponder, TCAS, TAS) antenna.

The Transponder Interrogator Antenna can be no closer than 4 feet from your Mode C Transponder antenna.

Failure to adhere to these critical installation notes could result in failure of the Transmitter and/or other radio equipment in said aircraft and will void your warranty.

## **2.1 ATC Surveillance Services**

Air Traffic Control (ATC) Surveillance Services are accomplished through the UAT data link technology. To use these services there must be a “single point of entry” for the ATC assigned squawk code. A single point of entry allows the squawk code to be transmitted by both the onboard Transponder as well as the SkyGuardTWX UAT Transmitter. The SkyGuardTWX UAT Transmitter supports the following control panel interfaces for acquiring an ATC assigned squawk code:

Compatible Transponders may be configured to act as a control panel for the SkyGuardTWX ADS-B UAT Transmitter. These transponders are: GTX™ 320, GTX™ 327, GTX™ 330, King KT76, Narco, Tera. Other Transponders may also be used but have not been tested with the SkyGuardTWX Transmitter.

## 2.2 Flight Manual Supplement

The Aircraft Flight Manual Supplement for installations of the SkyGuardTWX UAT Transmitter must include the following operational limitations:

When the transmitter is set to Standby or OFF the transmitter stops transmitting ADS-B messages after a time period of 2 seconds. The ADS-B ground stations only transmit Traffic Information Services – Broadcast (TIS-B) and ADS-Rebroadcast (ADS-R) messages to participating aircraft. Participating aircraft are identified as aircraft transmitting ADS-B messages. When the transmitter is set to Standby or OFF an ADS-B IN receiver no longer receives TIS-B and ADS-R messages from the ADS-B ground stations that were specifically generated for a unique transmitting aircraft because that aircraft is not participating in the ADS-B surveillance system.

For all installations that include a traffic display, the following must be included in the Flight Manual Supplement:

“Caution: Traffic shown on the display may or may not have traffic alerting available.”

For all installations that do not contain an aircraft Transponder, the following must be included in the Flight Manual Supplement:

“ATC assigned squawk codes may be entered into the ADS-B radio manually. This is accomplished using a dedicated control head or using a software app. capable of communicating with the ADS-B radio. Once such app. for the Apple iPad/iPhone is SkyGuardTWX which is available for free download from the Apple Store.”  
The Vision-Pro Plus transmitters have a squawk detector circuit to retrieve the Mode C Transponder squawk code and pressure altitude code.

## 2.3 Other Considerations

The SkyGuardTWX Transmitter is used as an aid to visual acquisition of traffic and weather and it is to be used only for pilot and crew situational awareness.

The SkyGuardTWX Transmitter does not relieve the flight crew of seeing and avoiding traffic, obstacles, and weather. Installation of the SkyGuardTWX Transmitter does not relieve the pilot of consulting approved data sources prior to and during each flight. The SkyGuardTWX Transmitter is not a collision avoidance device. Any deviation from ATC clearance, given cockpit information derived from the SkyGuardTWX Transmitter, must be approved by ATC.



### **3.0 Equipment Installation**

#### **3.1 Package Contents**

SkyGuardTWX Transmitter ADS-B radio unit  
DC Power connector plug  
Interrogator antenna  
1090 mhz receiver antenna (for use when no belly mounted antenna is installed)  
WiFi antenna  
GPS antenna  
Mounting bracket  
Installation manual  
(no external antennas are included)

#### **3.2 Specifications**

This section includes the physical, environmental, electrical, and performance specifications for the SkyGuardTWX UAT ADS-B Transmitter.

##### **Physical:**

Height:	1.920 inches (includes mounting bracket)
Width:	4.600 inches (includes mounting bracket)
Length:	9.300 inches (includes mounted antennas)
Weight:	1.4 lbs (excluding antenna cables and power cable)

##### **Environmental:**

The SkyGuardTWX ADS-B Transmitter is designed and tested to meet the categories as defined in RTCA/DO-160F:

Operating temperature:	-20°C to +55°C
Storage temperature:	-55°C to +85°C
Temperature variation:	5°C per minute
Humidity:	95% at 50°C
Maximum continuous altitude:	25,000 feet
External Cooling:	Not required

##### **Electrical:**

Voltage:	10-30VDC
Input Current (5W nominal):	Steady State: 0.3A @ 13VDC, 0.25A @ 28VDC Transmit Peak: 2.5A @ 13VDC, 2.4A @ 28VDC

**UAT Performance:**

TSO Compliance:	TSO-C154c
Regulatory:	RTCA/DO-282B
Frequency:	978MHz
Tolerance:	+/- 20ppm
Data Rate:	1.04167 Mbps
Receiver Sensitivity:	Exceeds 90%MSR@-91dBm
Transmit Power:	30W nominal
Equipment Class:	B1S (single bottom UAT antenna)

**Uncertified Internal GPS/WAAS Receiver Performance  
(P/N: UAT1000B-EX)  
Compliant to 91.227 requirements**

Number of channels:	50 (SBAS, WAAS, RAIM)
Frequency:	1575.42MHz L1
Sensitivity (Tracking Mode):	-162dBm
Sensitivity (Reacquisition Mode):	-160dBm
TTFF Hot (valid almanac, position, time and ephemeris):	1 second (average)
TTFF Warm (valid almanac, position and time):	< 30 seconds (average)
TTFF Cold (valid almanac):	< 60 seconds (average)
Reacquisition (<10seconds obstruction):	0.1seconds (average)
Position Update Interval:	5 Hz
Velocity:	1,000 m/s maximum @ 60,000 ft MSL
Datum:	WGS-84

**Avionics Interfaces:  
(DB 9 I/O Connector)**

Annunciator Output:	Capable of driving a +5 VDC LED lamp
Transponder Squawk Code input:	Wireless from aircraft Mode A/C/S Transponder
Pressure Altitude Encoder Input:	Wireless from aircraft Mode C/S Transponder
Display/Control Input/Output (optional):	RS232 asynchronous serial at 460,800 Baud

### **3.3 System Interfaces**

The SkyGuardTWX UAT Transmitter must be configured so that it will acquire a Transponder squawk code and pressure altitude code from the “Ownship” Transponder. This is accomplished with the automatic squawk detector circuit contained in the Vision-Pro Plus Transmitter.

### **3.4 Antenna Requirements/Installation**

If the SkyGuardTWX Transmitter (P/N: UAT1000B-EX) is configured to use the internal non-certified GPS as its position source. The provided GPS antenna must be attached to the GPS antenna port on the transmitter. The antenna performance is critical to the operation of the GPS/WAAS receiver.

The performance of the GPS/WAAS Receiver is affected by the gain, noise figure, impedance, and frequency selectivity characteristics of the antenna and the placement of this antenna within the aircraft. The transmitter should be used only with the provided antenna and cable. Use of other antennas and cables may not meet all of the performance characteristics specified.

The SkyGuardTWX UAT Transmitter (P/N: UAT1000B-EX) utilizes an active GPS antenna which means that the antenna includes a low noise amplifier. The power for the low noise amplifier is provided from the GPS receiver via the GPS antenna cable.

The GPS antenna must be installed inside the aircraft with a clear view of the upward sky. At least 6 satellites must be acquired in order to maintain a valid GPS location fix.

The SkyGuardTWX Transmitter requires one 978mhz UAT antennas meeting the following specification: standard 50Ω vertically polarized antenna with a VSWR < 1.7:1 at 978MHz. This UAT antenna must be installed on the bottom side of the aircraft fuselage.

A list of recommended 978mhz antennas for use with this transmitter are below:

Delta POP “Wing” (978mhz – experimental aircraft)

Rami AV-74 “Wing” (978mhz – certified aircraft)

Rami AV-22 “Ball and Stick” (1090mhz – certified aircraft)

Operating the SkyGuardTWX Transmitter without RF terminations on the UAT Transmitter Antenna port can result in equipment damage. Operate the transmitter only with the UAT Transmitter antenna port terminated with a VSWR ratio of 2.0:1 or less attached to this antenna port.

### 3.5 Temperature/Air Flow Requirements

The SkyGuardTWX Transmitter meets all DO-282B requirements without external cooling. However, as with all electronic equipment, lower operating temperatures will extend equipment life. It is not recommended to use “outside aircraft” forced air to cool the unit. Instead it is recommended that the unit be mounted in a location that contains an electric forced air fan to assist in cooling the equipment. If this is not possible, then install the unit in an area where the ambient air temperature does not exceed +40C. Do not mount the transmitter where it will receive direct sunlight as the radiated heat induced from the sunlight may cause the unit to exceed its maximum temperature rating.

### 3.6 Installation Mounting

The SkyGuardTWX Transmitter should be mounted to a rigid surface able to withstand inertial forces imposed by the 1.4 pound unit. The transmitter may be mounted using 4 bolts/nuts and 8 washers where the washers are placed on both the bolt side and nut side. Refer to the bolt/nut fastener manufacturer for torque guidelines. The SkyGuardTWX Transmitter should be connected to the airframe ground via the mounting bolts with braided strap to airframe ground.

Figure 2 below describes the Transmitter mounting bracket and attachment bolt pattern:

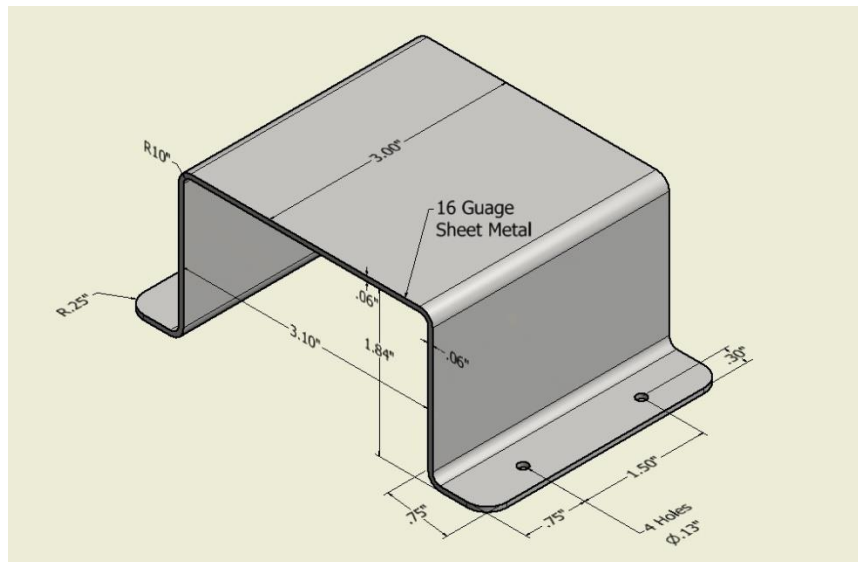

Figure 2: Transmitter Mounting Bracket

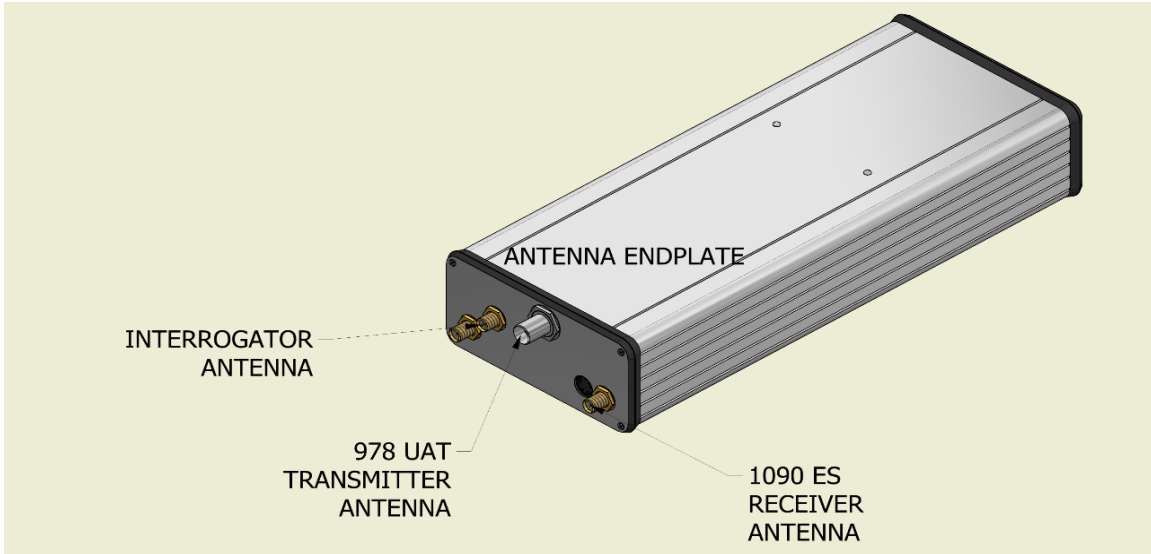

Figure 3: External Antenna Connections

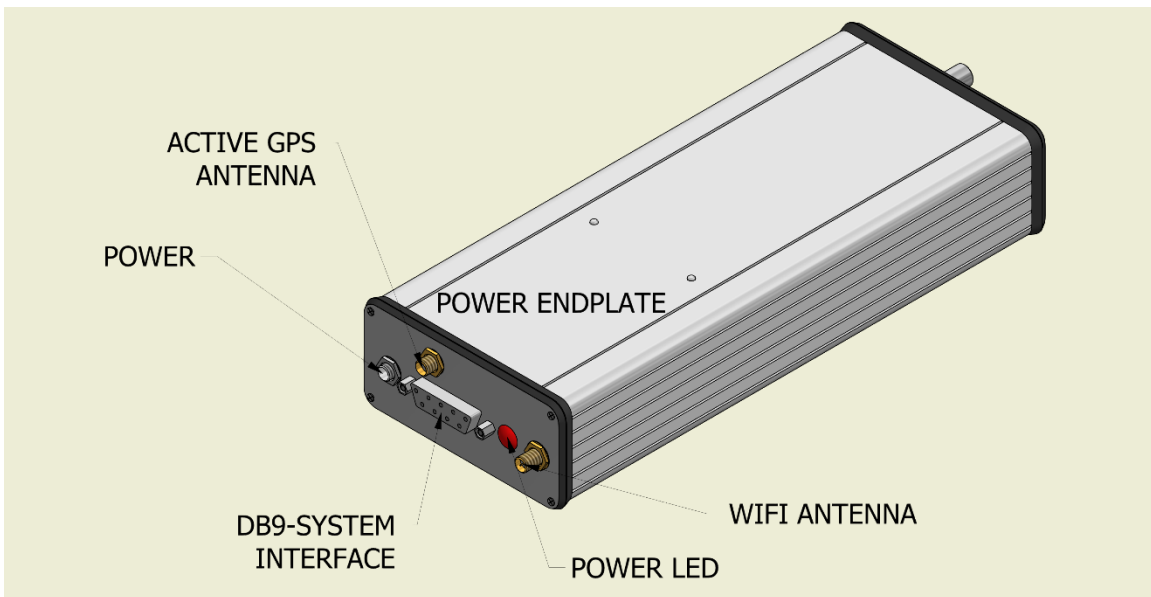

Figure 4: System I/F and Power Connections

The external GPS antenna should not be mounted close to VHF COM transmitter antenna, and other antennas emitting high power. Special care should be taken to ensure that the GPS antenna is not mounted in close proximity to antennas that may emit harmonic interference at the L1 frequency of 1575.42 MHz.

The external GPS antenna placement guidelines can be found in AC 20-138A section 16. For best performance, select an antenna location with an unobstructed view of the sky above the aircraft when in level flight.

The external UAT Transmitter Antenna **MUST** be installed no less than 4 feet from any Distance Measuring Equipment (DME) antenna.

The external UAT Transmitter Antenna **MUST** be installed no less than 4 feet from any Comm. Radio Antenna.

The external UAT Transmitter Antenna **MUST** be installed no less than 3 feet from any Transponder Radio Antenna.

The Transmitter Receiver Antenna(1090ES) **MUST** be installed no less than 2 feet from the UAT Transmitter antenna(978) and no less than 3 feet from any L-Band (Transponder, TCAS, TAS) antenna.

The Transponder Interrogator Antenna can be no closer than 4 feet from your Mode C Transponder antenna.

Failure to adhere to these critical installation notes could result in failure of the Transmitter and/or other radio equipment in said aircraft and will void your warranty.

RG-400 coaxial cable is required for the UAT Transmitter antenna. UAT Antenna cable loss should not exceed 2 dB. A 9 foot RG400 coaxial cable composed of RG400 1.5 dB loss. Limit the RG400 cables length to a maximum of 10 feet.

### 3.7 Electrical Connections

After the DB9 cable assembly is constructed to interface with the panel annunciator light and optionally a panel mounted display and installed on the SkyGuardTWX Transmitter, route the wire bundle as appropriate. Use cable ties to secure the cable assembly. Any ring terminals that are affixed to any cable shields of the cable assembly should be attached to the transmitter ground via one of the 4 mounting screws that secure the unit mounting bracket. The transmitter should be installed in accordance with Reference to AC 43.13-1B Chapter 11. Refer to:

- ✓ The cable assembly should not be exposed to wire chafing
- ✓ The cable assembly should not be located near the fuel lines.
- ✓ The cable assembly should not be located near high electrical capacity lines.
- ✓ The cable assembly should not be routed near high energy sources.
- ✓ The cable assembly should not be located near the flight control cables.
- ✓ Isolate the cable assembly from the engine.
- ✓ Install cable assembly in a protected area of the aircraft.
- ✓ Grounding pigtailed should not exceed more than 4 inches in length.
- ✓ Use 24 AWG or larger for all wiring except for power.
- ✓ Use 18 AWG or larger for power wiring.

A 9 pin D-Sub connector (female) interfaces to external equipment. This connector can be found at the rear of the SkyGuardTWX Transmitter unit. The following list shows the definition of the individual pins in this connector.

- Pin 1 - for future use
- Pin 2 - External Display RS232 Serial Output @ 460,800 Baud
- Pin 3 - for future use
- Pin 4 - for future use
- Pin 5 - Ground
- Pin 6 - for future use
- Pin 7 - External Display RS232 Serial Input @ 460,800 Baud
- Pin 8 - for future use
- Pin 9 - External Annunciator Light (LED) (+5 VDC)

### **3.71 Power Connection**

The Transmitter power connector to interface with aircraft power can be found at the rear end of the SkyGuardTWX unit. A specific “locking power plug” is included as part of the installation kit. The center conductor of this power plug should be connected to the + VDC power source for the unit. The shield conductor of this power plug should be connected to the Ground power return for the unit. The transmitter primary power source as supplied by the aircraft avionics power bus should have an inline circuit breaker rated at 5 amps and an on/off switch. The installed ON/OFF switch should be labeled:

“ADS-B Transmitter ON/OFF”.

The unit will operate utilizing a DC power source ranging from +10 volts to +30 volts with a minimum of 3 amps of current. The power supply cable going from the inline circuit break to the SkyGuardTWX Transmitter should be composed of 18 gauge or larger stranded wire.

### **3.72 Display Connection (Currently NOT Implemented)**

The SkyGuardTWX Transmitter supports interfacing with a panel mounted display for depiction of GPS position data and configuration. If a fixed display is intended to be used for this installation, then there are three PCB jumpers that must be configured inside the transmitter housing. Contact SkyGuardTWX for further instructions on how to set these jumpers.

The desired panel display must support the GDL90 software protocol running over an RS232 Serial Data Link. This data link must support either 460,800 serial baud rate. Connect the panel display RS232 input line to DB9-pin 2. Connect the panel display RS232 output line to DB9-pin 3. Connect the panel display Ground to DB9-pin 5. Contact the display manufacturer to insure it supports the above requirements prior to performing the install.

If an external panel display is selected, then the transmitter internal WiFi network will be disabled.



### **3.73 Transmitter Hardwired Connection (optional)**

The SkyGuardTWX Transmitter supports interfacing with a panel mounted Transponder for acquisition of transponder squawk codes and pressure altitude codes. Normally this would not be required as the SkyGuardTWX Transmitter contains a circuit that can wirelessly listen to the Transponder to collect the squawk code and pressure altitude code. If this is required, then a special version of Transmitter firmware will be required as well as additional internal jumper settings. Contact SkyGuardTWX for further details.

### **3.74 Annunciator Light Connection**

The SkyGuardTWX Transmitter supports control of a panel mounted Annunciator light. The light should be of an LED type and of color GREEN. The light should support a drive current of up to 25 milliamps at +5 VDC. The drive connection of this light should be connected to DB9 pin-9. The ground return connection of this light should be connected to DB9-5.

This light will initially come ON and begin blinking whenever the Transmitter is first powered on. Then once the transmitter has acquired a valid GPS position fix and the transmitter is determined to be ON and transmitting a valid ADS-B message, the light will go to a solid ON state. If for any reason the transmitter is found to be at fault and not transmitting, or the GPS position fix is found to be invalid, this light will blink ON/OFF. If your Mode C Transponder is set to non-altitude reporting mode, the light will blink ON/OFF.

A label showing “ADS-B Transmitter ON” should be affixed to the panel adjacent to the annunciator light.

#### 4.0 Initial Programming of Transmitter Configuration Parameters

After installation of the SkyGuardTWX UAT Transmitter with power and all antenna connections in place, the transmitter must be configured, prior to your first flight, to contain the following required parameters specific to the installed aircraft:

- N-number of installed aircraft
- ICAO code of installed aircraft
- Default ATC Squawk code

There are several options for configuring these parameters into the non-volatile memory of the transmitter. The primary method is to use a wireless tablet display with appropriate software which allows communication with the transceiver. There are several flight apps. available for IOS or Android tables that support configuration and update of the SkyGuardTWX Transmitter. There is also a dedicated programming application for the Apple iPad/iPhone which is available for download from the Apple App. Store under the name “SkyGuardTWX”.

- If using an iPad/iPhone to perform this initial configuration, first download the SkyGuardTWX app.
- Make sure you SkyGuardTWX Transmitter is powered on and has a valid GPS position fix.
- Then, on your Apple device, go into “Settings” and turn ON Airplane mode.
- While in “Settings”, turn on WiFi and after a brief search, a WiFi hot spot will appear showing “SkyGuardTWXxx” where “xx” is a numeric value specific to your ADS-B Transceiver.
- Select this WiFi hot spot by tapping on it’s name.
- Wait for approximately 10 seconds for the Apple device to establish a connection to the ADS-B transmitter over WiFi. If a connection is not established, turn off your WiFi on the Apple device and power cycle the transmitter. Then try again.
- Once connected, close “Settings” on the Apple device.
- Select the SkyGuardTWX app. on your iPad/iPhone or any other Flight App. that supports the SkyGuardTWX Vision-Pro UAT Transmitter on the Apple device.
- On the SkyGuardTWX app., you will see a main screen display showing N-number, ICAO, squawk code, and several other parameters. There are factory default values already stored into your Transmitters memory. The transmitter will not come on until you enter your specific aircraft values for these parameters.
- Next, enter the N-number of your installed aircraft.
- Enter the ICAO number for your aircraft. This number can be found by doing an N-number inquiry search on the [www.faa.gov](http://www.faa.gov) web site. Once you put in your n-number, the site will display a table of parameters about your specific aircraft. The ICAO number is on the right side of this table and is a 6 character alpha numeric number stated as “Mode S Code (base 15/hex).
- Enter a default squawk code of “1200” by using the number keys on the display.

- There are several other parameters that can be set/modified such as the following:  
Transmitter “ON/OFF”  
FIS-B “ON/OFF”  
TIS-B “ON/OFF”  
IDENT
- The status of these transmitter parameters are pre-set at the factory. You should leave these as they are for now.
- Once you make the final update, then press the “Resend Config” text button. This will cause the app. to send updates over the WiFi connection to the SkyGuardTWX Transmitter. These parameters will remain in memory even if you turn off the transmitter.
- In the future, you can turn off the transmitter by using this app. and pressing the “ON/OFF” text button to the right of “Transmitter”.
- Occasionally while in flight, ATC make request that you change your aircraft squawk code. The SkyGuardTWX UAT transmitter has the ability to listen to your Mode A/C/S Transponder and the squawk code it is currently transmitting. As you enter the ATC requested squawk code on your transponder, this number will get automatically updated into the SkyGuardTWX UAT Transmitter. Should you not have a Transponder in your aircraft, you can use the SkyGuardTWX app. to update this squawk code manually. There is also a manual “IDENT” button in this app. should ATC request you to IDENT your ADS-B Transmitter.
- Once your Transmitter has been initially configured, you should not have to go back and use one of the configuration apps. to make any changes. Each time you power on the transmitter, it will read the last stored parameters from its non-volatile memory.

## **5.0 Post Installation Verification**

After the Transmitter with all cabling, antennas, and power connections are installed, perform the following checks:

### **5.1 Transmitter Power Verification**

Remove the DC power connector to the Transmitter unit. Power up the aircraft avionics power bus. Using a DC multimeter, verify the voltage on the power cable is between +10 volts and +30 volts DC. If OK, then power OFF the aircraft avionics power bus. Then reconnect power cable back into the Transmitter unit and verify the red LED power light on the Transmitter unit is ON. With the power on for at least 5 minutes, verify that the inline 5 amp. circuit breaker does not trip.

### **5.2 GPS Verification**

Insure the GPS antenna is installed per section 3.6.

Power on the aircraft avionics power bus. Allow SkyGuardTWX Transmitter GPS to acquire a GPS position fix. Check flight moving map to insure aircraft position, altitude, heading and speed are all correct. Turn off the aircraft avionics power bus.

### **5.3 Pressure Altitude Encoder Verification (optional)**

Insure the altitude encoder is installed per section 3.73.

Power on the aircraft avionics power bus. Allow SkyGuardTWX Transmitter GPS to acquire a GPS position fix. Check flight moving map to insure aircraft pressure altitude is correct. Turn off the aircraft avionics power bus.

### **5.4 Transmitter UAT Transmit Verification**

Temporarily disconnect the RF coax wire from the UAT transmitter antenna and connect to an RF power meter. Set the center frequency of the power meter to 978mhz. Power on the aircraft avionics power bus. Allow SkyGuardTWX Transmitter GPS to acquire a GPS position fix. Once the transmitter is enabled and broadcasting, check the transmitter peak output power on the power meter. Readings should be between 28 watts and 32 watts. Turn off the aircraft avionics power bus. Disconnect the RF power meter and reattach RF coax cable to transmitter antenna.

### **5.5 Transmitter Annunciator Light Verification**

Power on the aircraft avionics power bus and Mode C Transponder with altitude reporting enabled. Verify the annunciator light is initially ON. Then allow SkyGuardTWX Transmitter GPS to acquire a GPS position fix. Once acquired, verify the annunciator light goes to a solid ON state. If the annunciator begins to flash ON/OFF at once per second, this is indicating that either you do not have the ADS-B transmitter enabled, or that you are not picking up the Transponder squawk and/or pressure altitude codes or you do not have a valid GPS position fix. Once the light goes solid ON and remains ON, then the Transmitter is working properly. Turn off the aircraft avionics power bus.

### **6.0 Weight and Balance**

Follow the guidelines in AC 43.13-1B, Chapter 10, Section 2. Update the aircraft equipment list indicating the items relocated, added or removed.

The weight of the SkyGuardTWX UAT Transmitter is 1.4 pounds not including antennas, antenna cables, and power wiring. Depending on where the unit is installed, the CG of the aircraft should be recalculated using standard methods utilizing the weight and arm values. Update the aircraft equipment list indicating the items relocated, added or removed.

## **7.0 Inflight Operation**

After aircraft avionics power is switched ON, verify that the red LED light on the endplate of the Transmitter is ON indicating power to the unit. Wait for the internal GPS to acquire a valid GPS position fix and lock. During the time the GPS is locking, you will see that green panel mounted “ADS-B Transmitter ON” light is OFF or blinking. This is indicating that the SkyGuardTWX Transmitter is NOT yet transmitting. Once the GPS has acquired a valid position lock, and the transmitter is determined to be operating ok, the annunciator light will go solid ON and the transmitter will begin broadcasting your position, altitude, heading, speed, etc. Should the annunciator light remain OFF or blinking, then verify you have a valid GPS position fix and/or verify the transmitter is configured and functioning properly.

Ensure your Transponder is on and transmitting so that the SkyGuardTWX Transmitter can acquire the desired squawk code and pressure altitude code. Should you not have a Transponder, you can enter the ADS-B squawk code using your flight display app. or the SkyGuardTWX Transmitter configuration app.

Depending on the type of flight display, verify that the GPS position of your aircraft matches where the aircraft is physically located.

During flight, you should see your aircraft maintain position/heading/speed/altitude on the moving map of your flight display.

When in range of an ADS-B ground station tower, you should begin to see receipts of Traffic (TIS-B) messages from this ground station tower.

Consult the manufacturer of your flight display moving map to determine how these messages are displayed.

08/01/2015

## **8.0 Maintenance**

### **8.1 Altitude Source**

The pressure altitude source provide to the SkyGuardTWX Transmitter must be tested and inspected every 24 months as referenced in FAR 91.411

### **8.2 Calibration**

There are no user-serviceable adjustments. There are no periodic maintenance functions to be performed on the SkyGuardTWX Transmitter.

### **8.3 Cleaning**

The SkyGuardTWX Transmitter does not require regular cleaning.

### **8.4 Tune-Up Procedure**

The SkyGuardTWX Transmitter is tuned at the factory. No tune-up procedure or servicing is required by the user. Should you suspect an issue with your Transmitter, then contact SkyGuardTWX for further instructions.

## 9.0

## Warnings and Disclaimers

### Disclaimer

SkyGuardTWX is not responsible for the failure of the NextGEN system and/or ADS-B radio station towers.

SkyGuardTWX is not responsible for any future changes to the NextGEN system that might make this ADS-B Transmitter incompatible with these changes.

SkyGuardTWX is not liable for damages as a result of use or misuse of this ADS-B Transmitter.

### **Important Pilot Advisory Note Regarding Safety of Radio Frequency Energy:**

Safe use of this device requires care as to the placement of the transmitter antenna. Place this antenna at least 20 cm (8 inches) away from any part of your body or that of other cabin occupants. Only handle the antenna when power is disconnected. Advise your passenger(s) to avoid contact with this antenna. Retain these instructions with your maintenance logs/files and for future reference.

### FCC Compliance Statement:

This device complies with part 15 of the FCC Rules. Operation is subject to the following two conditions:

1. This device may not cause harmful interference, and
2. This device must accept any interference received, including interference that may cause undesired operation.

Modifications not expressly approved by the manufacturer could void the user's authority to operate this equipment under FCC rules.

### FCC RF Radiation Exposure Statement:

This equipment complies with FCC RF radiation exposure limits set forth for a public/uncontrolled environment.

**WARNING:** This SkyGuardTWX Transmitter is to be used to improve pilot situational awareness only and as a navigational aid. It is not intended for primary navigation use in IFR flight conditions. SkyGuardTWX LLC is not responsible for the Transmitter's end use and will not be held liable for any events occurring from the use of the transmitter.